



*A Restatement of
the Classics...*



Offering Affordable Elegance & Style

For almost a third of a century, Turncraft has been helping homeowners, commercial builders, and residential contractors create grand entrances and dramatic interior accents. Turncraft has become “the source” for columns that offer affordable elegance and style. Each Turncraft column features thoughtful product design, fine workmanship in assembly, precision turning, and artful finishing.

Turncraft round columns may be ordered with or without fluting in standard shaft diameters and lengths from 6 inches by 6 feet to 20 inches by 20 feet, and in custom shaft diameters up to 30 inches and lengths to 30 feet. They are available in tapered and non-tapered versions and in a wide variety of plan styles. Square columns are also available in smooth or fluted designs.

Only prime construction materials and techniques are used in the creation of Turncraft columns, caps, and bases. Columns are customarily fashioned from staves made of select, kiln-dried Pine. The staves are assembled from finger-jointed pieces to conserve valuable wood resources and to reduce the possibility of warpage and bow. This superior construction technique is both environmentally friendly and structurally sound—minimizing pressures on critical joints and preventing checking or cracking of finished surfaces. Six inch through twelve inch Colonial Columns are equipped with Poly-U-Rim bases specially designed to



POLY-U-RIM™
CAPS & BASES

Design No.	Nominal Shaft		Tapered Shaft			Non-Tapered Shaft		Fluting Specs			Cap & Base		
	Dia.	Height	Outside Dia.		Inside Dia.	Diameter		No.	Width	Length	Shaft L.	Set	
1066	6"	6'	5-5/8"	4-1/4"	3"	1-3/4"	5-5/8"	3"	15	1/2"	4' 2"	5' 7"	2006
1068	6"	8'	5-5/8"	4-1/4"	3"	1-3/4"	5-5/8"	3"	15	1/2"	6' 2"	7' 7"	2006
1086	8"	6'	7-5/8"	6-1/4"	5"	3-1/2"	7-5/8"	5"	15	7/8"	4' 2"	5' 7"	2008
1088	8"	8'	7-5/8"	6-1/4"	5"	3-1/2"	7-5/8"	5"	15	7/8"	6' 2"	7' 7"	2008
0810	8"	10'	7-5/8"	6-1/4"	5"	3-1/2"	7-5/8"	5"	15	7/8"	6' 2"	9' 7"	2008
1106	10"	6'	9-5/8"	8-1/4"	7-1/8"	5-1/2"	9-5/8"	7-1/8"	18	7/8"	4' 2"	5' 7"	2010
1108	10"	8'	9-5/8"	8-1/4"	7-1/8"	5-1/2"	9-5/8"	7-1/8"	18	7/8"	6' 2"	7' 7"	2010
1110	10"	10'	9-5/8"	8-1/4"	7-1/8"	5-1/2"	9-5/8"	7-1/8"	18	7/8"	8' 2"	9' 7"	2010
1112	10"	12'	9-5/8"	8-1/4"	7-1/8"	5-1/2"	9-5/8"	7-1/8"	18	7/8"	10' 2"	11' 7"	2010
1128	12"	8'	11-5/8"	10-1/4"	9"	7-1/2"	11-5/8"	9"	20	7/8"	6' 2"	7' 7"	2012
1210	12"	10'	11-5/8"	10-1/4"	9"	7-1/2"	11-5/8"	9"	20	7/8"	8' 2"	9' 7"	2012
1212	12"	12'	11-5/8"	10-1/4"	9"	7-1/2"	11-5/8"	9"	20	7/8"	10' 2"	11' 7"	2012
1216	12"	16'	11-5/8"	10-1/4"	9"	7-1/2"	11-5/8"	9"	20	7/8"	14' 2"	15' 5"	2012
1408	14"	8'	13-5/8"	11"	10-3/4"	7-3/4"	13-5/8"	10-3/4"	24	7/8"	5' 11"	7' 5"	2514
1410	14"	10'	13-5/8"	11"	10-3/4"	7-3/4"	13-5/8"	10-3/4"	24	7/8"	7' 11"	9' 5"	2514
1412	14"	12'	13-5/8"	11"	10-3/4"	7-3/4"	13-5/8"	10-3/4"	24	7/8"	9' 11"	11' 5"	2514
1414	14"	14'	13-5/8"	11"	10-3/4"	7-3/4"	13-5/8"	10-3/4"	24	7/8"	11' 11"	13' 5"	2514
1416	14"	16'	13-5/8"	11"	10-3/4"	7-3/4"	13-5/8"	10-3/4"	24	7/8"	13' 11"	15' 5"	2514
1418	14"	18'	13-5/8"	11"	10-3/4"	7-3/4"	13-5/8"	10-3/4"	24	7/8"	15' 11"	17' 5"	2514
1610	16"	10'	15-5/8"	13"	13"	10"	15-5/8"	13"	24	1"	7' 11"	9' 5"	2516
1612	16"	12'	15-5/8"	13"	13"	10"	15-5/8"	13"	24	1"	9' 11"	11' 5"	2516
1616	16"	16'	15-5/8"	13"	13"	10"	15-5/8"	13"	24	1"	13' 11"	15' 5"	2516
1618	16"	18'	15-5/8"	13"	13"	10"	15-5/8"	13"	24	1"	15' 11"	17' 5"	2516
1620	16"	20'	15-5/8"	13"	13"	10"	15-5/8"	13"	24	1"	17' 11"	19' 5"	2516
1810	18"	10'	17-5/8"	15"	14-3/4"	12"	17-5/8"	14-3/4"	27	1"	7' 11"	9' 5"	2518
1812	18"	12'	17-5/8"	15"	14-3/4"	12"	17-5/8"	14-3/4"	27	1"	9' 11"	11' 5"	2518

provide increased durability—no joint separation—and easy installation. These polyurethane caps and bases are reaction injection molded (RIM) to ensure crisp detail and consistency. Fourteen inch and larger Colonial Columns come with standard polyurethane caps and bases. Optional aluminum plinths are available for applications that require an extra measure of protection.

The process of making Turncraft columns begins with the milling of the finger-jointed or solid staves to exacting dimensions. Aligned with tongue-n-groove joints, the staves are then assembled into a raw shaft using the strongest Type-I waterproof glue. Torque bands are wrapped around the shaft approximately every 12 to 18 inches. These bands apply pressure of 90 to 100 pounds per square inch while the glue cures for a full 24 hours or more, transforming the individual staves into an inseparable unit, ready for turning.

All paint-grade wood shafts, caps, and bases are fully immersed in Woodtreat® MB preservative for a minimum of five minutes per inch of stave thickness. Woodtreat MB is a clear, water-repellent wood preservative solution that penetrates deep into the wood. It has been formulated for maximum compatibility with paint primers and topcoats. The 3-iodo-2 propynyl butyl carbamate formula provides effective protection against mold, mildew, and staining and decaying fungi. It improves the dimensional stability and aids in the control of shrinking, swelling, end checking, splitting, grain raising, and warping. It conforms to Industrial Standard IS4-81, is approved by N.W.W.D.A., and meets all current and proposed government standards.



Load-Bearing Capacities

Design No.	Tapered Shaft						Non-Tapered Shaft				Fluting Specs			Cap & Base	
	Nominal Shaft		Outside Dia.		Inside Dia.		Diameter		No.	Width	Length	Shaft L.	Set	Shaft Dia.	Lbs.
	Dia.	Height	Bottom	Top	Bottom	Top	Out.	In.							
1816	18"	16'	17-5/8"	15"	14-3/4"	12"	17-5/8"	14-3/4"	27	1"	13' 11"	15' 5"	2518	6"	2,095
1818	18"	18'	17-5/8"	15"	14-3/4"	12"	17-5/8"	14-3/4"	27	1"	15' 11"	17' 5"	2518	8"	3,258
1820	18"	20'	17-5/8"	15"	14-3/4"	12"	17-5/8"	14-3/4"	27	1"	17' 11"	19' 5"	2518	10"	4,268
1916	20"	16'	19-5/8"	17"	16-7/8"	14"	19-5/8"	16-7/8"	27	1"	13' 11"	15' 5"	2520	12"	5,173
1918	20"	18'	19-5/8"	17"	16-7/8"	14"	19-5/8"	16-7/8"	27	1"	15' 11"	17' 5"	2520	14"	6,808
1920	20"	20'	19-5/8"	17"	16-7/8"	14"	19-5/8"	16-7/8"	27	1"	17' 11"	19' 5"	2520	16"	8,618
2216	22"	16'	21-5/8"	19"	18-1/4"	15-3/4"	21-5/8"	18-1/4"	28	1-1/2"	14' 1"	15' 5"	2522	18"	10,624
2218	22"	18'	21-5/8"	19"	18-1/4"	15-3/4"	21-5/8"	18-1/4"	28	1-1/2"	16' 1"	17' 5"	2522	20"	11,915
2220	22"	20'	21-5/8"	19"	18-1/4"	15-3/4"	21-5/8"	18-1/4"	28	1-1/2"	18' 1"	19' 5"	2522	22"	18,905
2222	22"	22'	21-5/8"	19"	18-1/4"	15-3/4"	21-5/8"	18-1/4"	28	1-1/2"	20' 1-1/2"	21' 5"	2522	24"	20,974
2224	22"	24'	21-5/8"	19"	18-1/4"	15-3/4"	21-5/8"	18-1/4"	28	1-1/2"	22' 1-1/2"	23' 5"	2522	26"	23,221
2418	24"	18'	23-5/8"	21"	20-1/4"	17-3/4"	23-5/8"	20-1/4"	30	1-1/2"	16' 1"	17' 5"	2524	28"	25,476
2420	24"	20'	23-5/8"	21"	20-1/4"	17-3/4"	23-5/8"	20-1/4"	30	1-1/2"	18' 1"	19' 5"	2524	30"	27,736
2422	24"	22'	23-5/8"	21"	20-1/4"	17-3/4"	23-5/8"	20-1/4"	30	1-1/2"	20' 1-1/2"	21' 5"	2524		
2424	24"	24'	23-5/8"	21"	20-1/4"	17-3/4"	23-5/8"	20-1/4"	30	1-1/2"	22' 1-1/2"	23' 5"	2524		
2626	26"	26'	25-5/8"	23"	22-1/4"	19-3/4"	25-5/8"	22-1/4"	34	1-1/2"	24' 1-1/2"	25' 5"	2526		
2828	28"	28'	27-5/8"	25"	24-1/4"	21-3/4"	27-5/8"	24-1/4"	36	1-1/2"	26' 1-1/2"	27' 5"	2528		
2930	30"	30'	29-5/8"	27"	26-1/4"	23-3/4"	29-5/8"	26-1/4"	40	1-1/2"	28' 1-1/2"	29' 5"	2530		

Shaft Dia.	Lbs.	Shaft Dia.	Lbs.
6"	2,095	20"	11,915
8"	3,258	22"	18,905
10"	4,268	24"	20,974
12"	5,173	26"	23,221
14"	6,808	28"	25,476
16"	8,618	30"	27,736
18"	10,624		

Sample columns tested supported loads at least four times calculated value above prior to failure. Loads were applied concentrically through the axis of the column. Loads are valid only if there is uniform contact between the full area of the column ends and the cap and base units. Load values are provided for your convenience and are not exact. Consult a structural engineer for the most accurate load estimates.

Other sizes available. Call for specifications.

Length from Shaft Bottom to Taper:

Size	Feet	Size	Feet	Size	Feet	Size	Feet
6" x 8"	0	12" x 8"	0	16" x 12"	0	18" x 18"	6
8" x 8"	0	12" x 10"	2	16" x 16"	4	18" x 20"	8
8" x 10"	2	12" x 12"	4	16" x 18"	6	20" x 16"	4
10" x 8"	0	14" x 8"	0	16" x 20"	8	20" x 18"	6
10" x 10"	2	14" x 10"	2	18" x 12"	0	20" x 20"	8
10" x 12"	4	14" x 12"	4	18" x 16"	4		

22" through 30"
Diameters have 1/3
straight cylinder to
2/3 taper ratio.



Distilling Nature in Ornament

Turncraft Ornamental Capitals artfully capture natural themes and images in an artistic composite sculpture. For example, the volute scrolls of the Ionic, Erectheum, Scamozzi, and Empire imitate the helix cross-section found in the Nautilus shell. The Acanthus leaves on the Temple of Winds and Corinthian Capitals echo the flowering crown of a tree. These capitals are crafted from a number of materials including wood, plaster, and fibers and are shaped into the appropriate proportions for the various styles of architecture and sizes of column shafts.

Roman Ionic			
Bottom Shaft Dia.	Style	Cap Height	Abacus Width
6"	R106	2-1/4"	5-3/4"
8"	R108	3-1/4"	8"
10"	R110	3-7/8"	10-1/2"
12"	R112	4-3/4"	12-1/2"
14"	R114	5-1/4"	17-1/2"
16"	R116	5-3/4"	17-1/2"
18"	R118	6"	19-1/2"
20"	R120	8-3/4"	25"

Greek Erectheum			
Bottom Shaft Dia.	Style	Cap Height	Abacus Width
6"	GE06	3-1/2"	7-1/2"
8"	GE08	3-7/8"	8"
10"	GE10	5-3/4"	12"
12"	GE12	6-3/4"	15"
14"	GE14	7"	14"
16"	GE16	9"	17"
18"	GE18	10-1/4"	22"
20"	GE20	11"	26"

Scamozzi			
Bottom Shaft Dia.	Style	Cap Height	Abacus Width
6"	SC06	2-1/2"	7-1/2"
8"	SC08	4"	11-1/2"
10"	SC10	4"	13-1/2"
12"	SC12	4-3/4"	16-1/4"
14"	SC14	5-3/4"	18"
16"	SC16	6"	21-1/2"
18"	SC18	6-1/4"	23"
20"	SC20	8-3/4"	26"

Roman Doric Ornamental			
Bottom Shaft Dia.	Style	Cap Height	Abacus Width
6"	RD06	4"	8-3/4"
8"	RD08	5"	11"
10"	RD10	5-3/4"	14"
12"	RD12	7-1/2"	16"
14"	RD14	8-1/2"	17-1/2"
16"	RD16	9"	20"
18"	RD18	14-1/4"	28"

Greek Angular Ionic			
Bottom Shaft Dia.	Style	Cap Height	Abacus Width
6"	GA06	3-1/8"	8"
8"	GA08	3-3/4"	9-1/4"
10"	GA10	5-3/4"	15"
12"	GA12	6"	17"
14"	GA14	8"	20"
16"	GA16	8-1/2"	22"
18"	GA18	9-3/4"	24-1/4"
20"	GA20	11"	29-3/4"

Empire			
Bottom Shaft Dia.	Style	Cap Height	Abacus Width
6"	EM06	3"	8-1/4"
8"	EM08	3-3/4"	9-3/4"
10"	EM10	5-3/4"	13"
12"	EM12	6-1/2"	17-1/2"
14"	EM14	7-3/4"	22"
16"	EM16	9"	22-1/2"
18"	EM18	9-3/4"	30-1/4"
20"	EM20	11-1/4"	34"

Temple of Winds			
Bottom Shaft Dia.	Style	Cap Height	Abacus Width
6"	TW06	7"	8"
8"	TW08	7-3/4"	12"
10"	TW10	11-1/4"	15"
12"	TW12	11-3/4"	16-3/4"
14"	TW14	16"	18-1/2"
16"	TW16	16"	23"
18"	TW18	18-1/2"	26"
20"	TW20	23"	29"

Roman Corinthian			
Bottom Shaft Dia.	Style	Cap Height	Abacus Width
6"	RC06	7"	9-1/2"
8"	RC08	10"	12-1/2"
10"	RC10	11-1/2"	14"
12"	RC12	11-3/4"	18-1/2"
14"	RC14	17-1/2"	22"
16"	RC16	18"	24"
18"	RC18	23"	31"

Composition Ornamental Capitals are coated with boiled linseed oil and turpentine as a temporary protector. Must be primed and coated with at least two coats of oil-base paint on the inside and outside. (If capitals are allowed to gather moisture before painting, peeling is likely to occur and further coating will be futile.) Ornamental Capitals are shipped with a load-bearing plug which must bear the weight of any load on the column.

All Ornamental Capitals ship FOB Factory.

Square Columns



Turncraft Square Colonial Columns are ideal for those situations in which a porch post is not quite enough and a round Colonial Column is too much. They are shipped unassembled and include matching caps and bases.

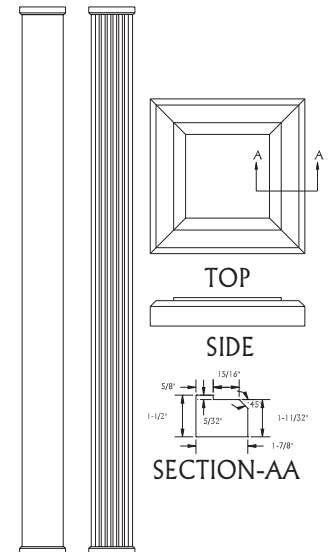

	Nominal W.	Inside H.	Base W.	Base W.	Base H.
6001	6"	8"	4"	6-3/16"	15/16"
6003	8"	8"	6"	8-3/16"	15/16"
6004	8"	10"	6"	8-3/16"	15/16"
6015	10"	8"	8"	10-3/16"	15/16"
6016	10"	10"	8"	10-3/16"	15/16"

Actual shaft height 1-5/16" less than nominal.



Plan Types

Turncraft Columns are available in the following plan types. Please specify when you order.

A	B	C	D
-	**	-	-



TC-CCB-200-1 TC3111 IP

Information and specifications within this brochure are subject to change without notice.

P.O. Box 2429
White City, OR 97503
(541) 826-2911
Fax (541) 826-1393

© 2000 TURNCRAFT. Printed in the USA.

Sample columns tested supported loads at least four times calculated value above prior to failure. Loads were applied concentrically through the axis of the column. Loads are valid only if there is uniform contact between the full area of the column ends and the cap and base units. Load values are provided for your convenience and are not exact. Consult a structural engineer for the most accurate load estimates.